



Discover Dôme universe on our website:
www.focal-dome.com

Due to constant technological advances, Focal-Jmlab® reserves its right to modify specifications without notice. Images may not conform exactly to specific product. Photos by L'Atelier Sylvain Madelon.



DÔME®



Focal-Jmlab® - BP 374 - 108, rue de l'Avenir - 42353 La Talaudière cedex - France

Tel. +33 4 77 435 700 - Fax +33 4 77 435 704 - www.focal-fr.com - © Focal-Jmlab 2008 - SCAB-080301

Dôme® is a registered model and trademark of Focal-Jmlab®. Focal®, Utopia®, Polyglass®, OPC® are trademarks of Focal-Jmlab®, BASH® is a trademark of Indigo™.



Focal invents DÔME®let yourself be seduced

Focal invents Dôme, a unique high-end miniature loudspeaker, designed to let you rediscover true musical performance, without constraints and without encroaching on your environment. A high-end loudspeaker through its design, the quality of the chosen materials, its "made in France" origin, its 100% Focal technology stemmed from the most

prestigious loudspeakers. High-end also in its performance, inversely proportional to the object size, that's to say radically different from what you could expect from mini-loudspeakers so far. Discover Dôme, a concentrate of Focal know-how. Let yourself be seduced...



> Created in 1980 by Jacques Mahul, Focal designs and manufactures its drivers and loudspeakers on its production site of Saint-Etienne. Between the "Grande Utopia Be" and Dôme, between the infinitely big and the infinitely small, there are almost 30 years of innovation and exclusive technologies dedicated to music.

DÔME[®], the sonic spotlight

Creating Dôme was to accept a real challenge. Because for Focal, whatever the loudspeaker, whatever its size, its price, the primary goal is to offer the best possible performance. This is the Focal sound, "The Spirit of Sound".

When we created the "Grande Utopia Be", it was almost easy: inventing the best loudspeaker in the World, without any size, price or means limitation, it was simply imagining the technologies to reach the ultimate goal.

With Dôme and its 5.5" (14cm) diameter only, it's a different story, since we wanted to have the maximum

music, in spite of these new constraints. A fascinating challenge that drove us to imagine new solutions, new shapes with noble materials, speakers with outstanding performance.

A body in die-cast aluminum alloy, an ultra-glossy black finish, Dôme design was thought to be functional, sophisticated, but clean in the extreme. Simple, its round shape itself is justified, it's perfect to avoid the creation of internal resonances (standing waves), which alter completely the tone purity. Everything is smooth, not a screw is visible, even the joint system on pivot is perfectly

integrated, unsuspected in spite of its complexity. Devised like a rotating "Sonic Spotlight", Dôme is a perfect music source for any room in the house, that we wished as essential as a light source.

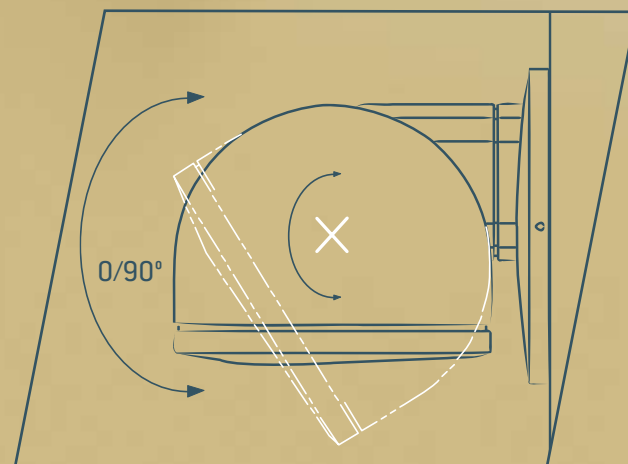

> The pivot system virtually placed in the loudspeaker center permits to tip over Dôme and to orientate it over 90°.



We manufacture the best speakers in the world...

Our commitment, which is one of a great brand of driver and loudspeaker manufacturing, is to enable you to take possession of the most sophisticated technologies.

With Dôme we had to go beyond new limits to conciliate contradictory requirements, such as power handling, bass extension, efficiency or definition thanks to our control of the speaker Science that we're been cultivating for almost 30 years.

All our know-how is included into Dôme, real 2-way loudspeaker equipped with all Focal sophistications: exclusive Polyglass cone, Aluminum/Magnesium inverted dome tweeter,

OPC crossover... Advanced technologies worked out for our made in France speakers on our production site of Saint-Etienne, that all aim at the research of a high-quality sound. Miniature loudspeaker indeed, but certainly a beautiful object too, Dôme has never turned away from our essential concern: offering a balanced, powerful and dynamic sound as any other Focal creation.



> Shape simplicity, but unconventional technical complexity to integrate Focal sound in Dôme.



> Polyglass® cone woofer and Aluminum/Magnesium alloy inverted dome tweeter: Focal exclusive technologies guarantee outstanding sound rendering.

...you just have to listen





> Made in die-cast Aluminum alloy, the Dôme Subwoofer body is made of one piece: a true technological exploit, guarantee of a perfect rigidity for irreproachable bass frequencies.

DÔME® Subwoofer incidentally essential

To go further with Dôme, we created Dôme Subwoofer. An amplified bass enclosure made on the same model, with its compact body cast in one piece of black lacquered aluminum. In 2.1 Stereo as in 5.1 Home Theatre use, the sound reaches an extent comparable to the one of a conventional loudspeaker... that is much bulkier. Rooms of big dimensions are not an obstacle any more for Dôme thanks to the dynamics and power of our miniature loudspeaker combined with its subwoofer. This was unbelievable so far for such a compact size! To reach this, Dôme Subwoofer is once again inspired by the best speaker technologies and a digital/analog hybrid BASH® type amplifier, adopted

on all Focal subwoofers, including the reference line Utopia Be. In Stereo as in Home Theatre installation, you will very soon discover that Dôme Subwoofer is the essential accessory to show the worth of our miniature loudspeaker Dôme.





On ceiling

DÔME®

As you wish...



On wall

On stand



Sober and sophisticated shapes, compactness, easy to install and to use, this is what makes Dôme an ultra-versatile loudspeaker to follow you anywhere in your environment. On a piece of furniture, a shelf or simply on the floor, fixed to the wall or to the ceiling and orientated towards the listening zone, Dôme possesses original high flexibility. It guarantees you the best performance thanks to thorough optimization.

And if this is not enough, an optional aluminum stand with a stable cast iron base is also available. The Dôme Subwoofer is designed to give the best of its abilities once placed in a room corner: its strength is at its maximum and its concealment in the room is total. That's convenient because in 90% of cases, a bass enclosure almost always ends up in a room corner where it is most discrete...



On furniture



> The sonic spotlight in color: the optional speaker front covers are available in blue, red and yellow jersey. A lacquered white version will be on sale in the second half of the year 2008.

DÔME®

...Where you wish

Bathroom



Bedroom

Incredibly flexible, Dôme can be used how and where you wish. In 2.0 stereo, without any dedicated subwoofer, its resources are sufficient for small rooms, for an office in centre-field listening, or as a very high-end background sound system in your environment, kitchen, bedroom or bathroom. In 2.1 version, with the Dôme Subwoofer, big spaces open up, the

system has no difficulty to fill up a living-room of 40m² (or even 60m²), without straining even at high level. And in a 5.1 Home Theatre installation, Dôme will become perfectly integrated in the environment of a Plasma or LCD flat screen thanks to its black glossy finish and its compactness.

Living-room



Kitchen



Dôme all worked up...



Dôme Pack 2.0

Ideal in a small room or on a desk for near field listening, a Dôme couple is sufficient thanks to the excellent performance of the bass frequencies. By putting them closer to a wall or to an angle, the bass level will be multiplied by a factor 4 thanks to the phenomenon of natural bass amplification (wall effect).



Dôme Pack 2.1

Also available in 2.1 version, Dôme is at its best in association with Dôme Subwoofer. Impact, power up to very big rooms, without restriction. The reproduction fullness, its generosity from the bass frequencies to the treble, reaches the one obtained with loudspeakers far bigger.



Dôme Pack 5.1

The Dôme 5.1 pack is the most accomplished Home Theatre solution that combines integration and high-level performance. Ideal complement for plasma and LCD screens, even with big diagonal, since the reproduction fullness is outstanding. This set can very easily evolve towards a 7.1 installation with the extra contribution of a Dôme 2.0 system.



	Dôme	Dôme Subwoofer
Type	2-way compact sealed speaker	Active bass-reflex subwoofer
Drivers	4" [10cm] Polyglass mid-bass, 1" [25mm] Al/Mg inverted dome tweeter	8" [21cm] Polyflex woofer
Frequency response [±3dB]	80Hz - 28kHz	42Hz - 200Hz
Low frequency point [-6dB]	72Hz	35Hz
Sensitivity [2.83V/1m]	88dB	Subwoofer features Variable crossover 50Hz to 200Hz, Phase inverter 0°/180°, Autopower, LFE input
Nominal impedance	8 ohms	
Minimum impedance	4 ohms	
Crossover frequency	2500Hz	
Recommended amplifier power	25 - 100W	100W BASH® amplifier
Dimensions [HxWxD]	6 ^{3/4} "x5 ^{11/16} "x5 ^{5/8} " [172x144x143mm]	15 ^{3/4} "x10 ^{7/8} "x10 ^{7/8} " [400x276x276mm]
Net weight	4.2lbs [1.9kg]	18lbs [8.2kg]



> Optional Dôme Stand, 33.5" (85cm)

Dôme at home, how?

Dôme 2.0

> The Dôme 2.0 pack is connected to a simple stereo amplifier, which is itself linked to the audio source (CD, DVD,...). Dôme is then connected like any other traditional loudspeaker.

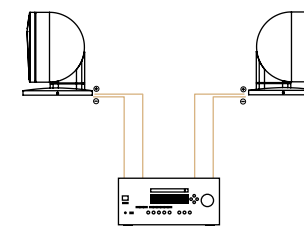

Dôme 2.1

> The Dôme 2.1 pack is connected to a 2.1 system, a unity that integrates in the same element a DVD (or CD) player, a 2-channel amplifier and a RCA line output Sub: the most practical way to listen to music or to watch a video.

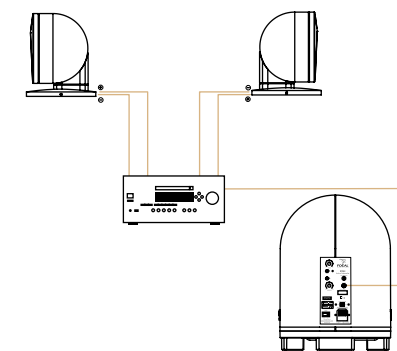

Dôme 2.1

> Dôme 2.1 can be connected to a standard stereo amplifier without a subwoofer output thanks to an optional dedicated connector, available in the second half of the year 2008 according to the country.

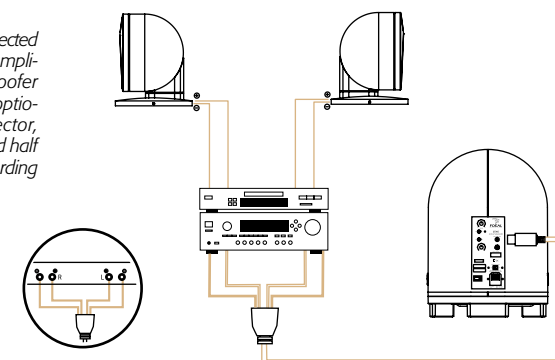

Dôme 5.1

> Dôme 5.1 can be connected to the audio video amplifier like any other 5.1 system. In that case, we recommend that you use these loudspeakers in "Small" mode in the amplifier configuration menu.

